

1	glass2	1
2	Fixture cover	1
3	The naterproof aprons	1
4	Display board	1
5	Fixture holder	1
6	Adapter plate	1
7	Wireless fixed board	1
8	Wireless receiving board	1
9	LED board	1
10	Control board	1
11	Lens	4
12	Wireless antenna	1
13	Control panel	1
14	Cover glass	1
15	Top cover of fixture holder	1
16	IP powercon IN	1
17	Abracket	1
18	Battery	1
19	Switch	1
20	The following fixture housing	1
21	The following waterproof apron	1
22	Charging panel	1
23	Power supply	1
24	Base under the cover	1
25	Machine foot	4
26	The insurance rope	1

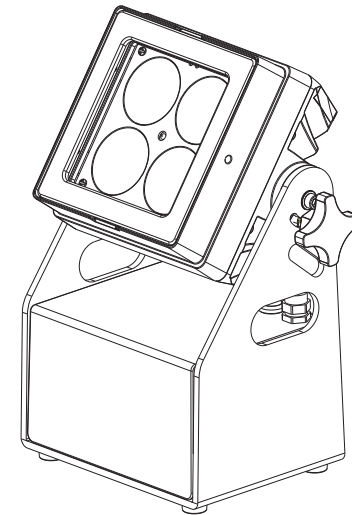

# Kubo4

## USER MANUAL

# 1 PRODUCT TECHNICAL PARAMETERS

## 1.1 PRODUCT STANDARD

VOLTAGE	AC100~240V 50/60HZ
POWER	30W
IP RATING	IP 65
TEMPERATURE (C)	-20~40
PCS	R/G/B/L*4PCS
MEASURE (mm)	223X132X274mm
WEIGHT (KG)	6.3KG

## 1.2 SIZE CHART

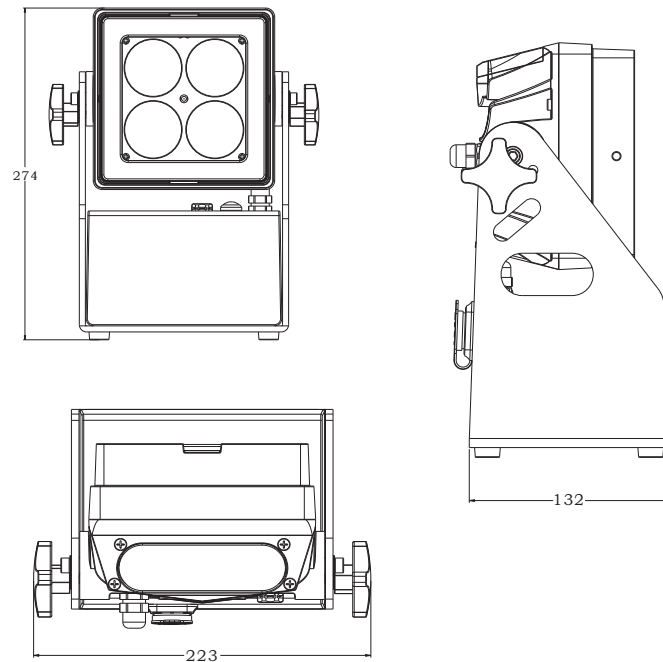

# 7 APPENDIX

## 7.1 MAINTENANCE

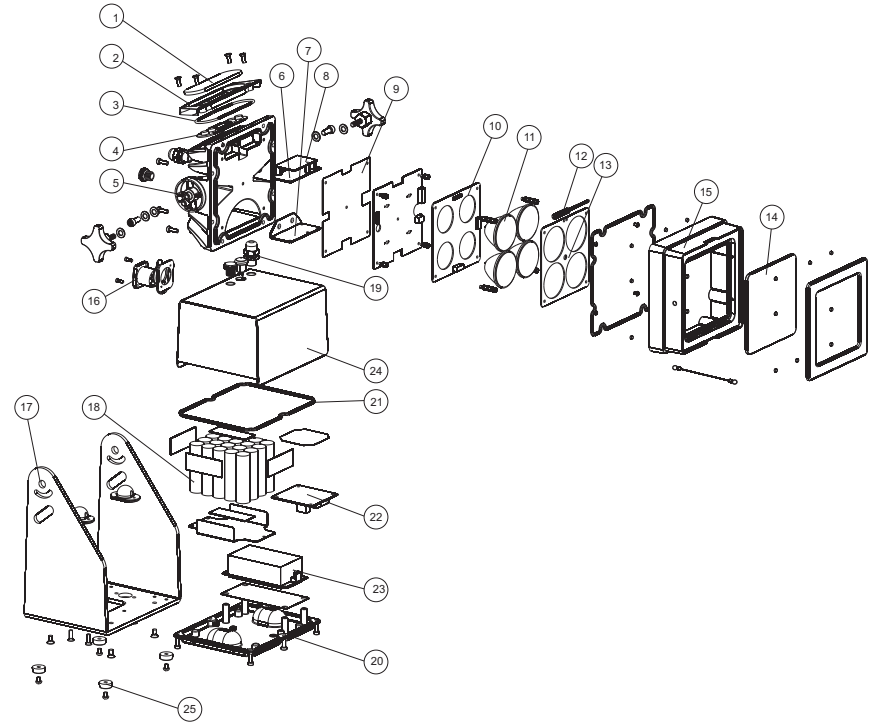

## 6 OPERATION WITH WIRELESS DMX

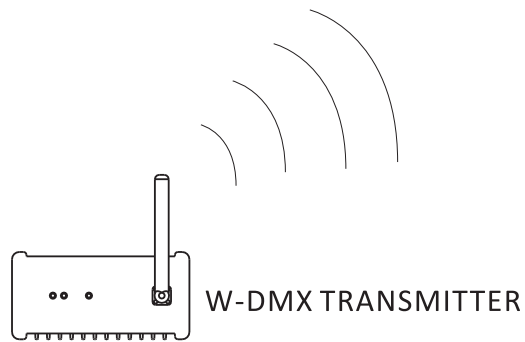

- 6.1 When using this lighting fixture with W-DMX receiver installed inside, the fixture may be placed at a range of 200m from W-DMX transmitter
- 6.2 Select DMX from the <RUN> menu.
- 6.3 By pressing the RESET button on W-DMX transmitter, transmitter will search for RESET lighting fixtures. During search transmitter green SIGNAL indicator will flash. After pairing with lighting fixture green SIGNAL indicator will display.

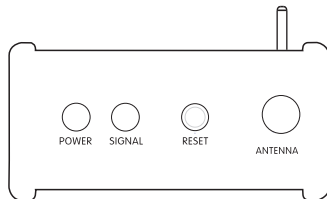

- 6.4 Once a lighting fixture has been paired with a W-DMX transmitter, the green SIGNAL indicator will display. Once a lighting fixture has been paired with a W-DMX transmitter, the lighting fixture cannot be paired with another W-DMX transmitter. If a lighting fixture requires pairing with a new W-DMX transmitter, steps 5.3 and 5.4 must be repeated.

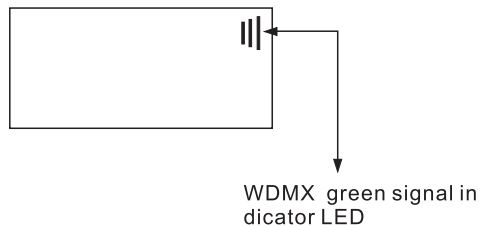

## 1.3 SAFETY WARNING

### IMPORTANT

[ALWAYS READ THE USER MANUAL BEFORE OPERATION.]  
[PLEASE CONFIRM THAT THE POWER SUPPLY STATED ON THE PRODUCT IS THE SAME AS THE MAINS POWER SUPPLY IN YOUR AREA.]

- This product must be installed by a qualified professional.
- Always operate the equipment as described in the user manual.
- A minimum distance of 0.5m must be maintained between the equipment and combustible surface.
- The product must always be placed in a well ventilated area.
- Always make sure that the equipment is installed securely.
- DO NOT stand close to the equipment and stare directly into the LED light source.
- Always disconnect the power supply before attempting and maintenance.
- Always make sure that the supporting structure is solid and can support the combined weight of the products.
- The earth wire must always be connected to the ground.
- Do not touch the power cables if your hands are wet.

### ATTENTION



- This product left the place of manufacture in perfect condition. In order to maintain this condition and for safe operation, the user must always follow the instructions and safety warnings described in this user manual.
- Avoid shaking or strong impacts to any part of the equipment.
- Make sure that all parts of the equipment are kept clean and free of dust.
- Always make sure that the power connections are connected correct and secure.
- If there is any malfunction of the equipment, contact your distributor immediately.
- When transferring the product, it is advisable to use the original packaging in which the product left the factory.
- Shields, lenses or ultraviolet screens shall be changed if they have become damaged to such an extent that their effectiveness is impaired.
- The lamp (LED) shall be changed if it has become damaged or thermally deformed.



Caution, risk of electric shock  
The light source contained in this luminaire shall only be replaced by the manufacturer or his service agent or a similar qualified person.

## 2 INSTALLATION

### 2.1 MOUNTING

#### Horizontal placement:

First fix the hanging frame where it is placed, making sure the angle is adjustable, as shown in figure 2.1-1

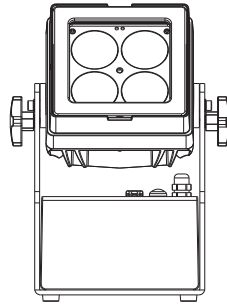

2.1-1

#### HANGING:

The LED MODULE can be mounted in a hanging position using the support frame. It is possible to use any bolt of the correct size and strength to mount the fixture. It is recommended to use at least 2 mounting points per fixture. Mounting with a clamp or other mounting bracket is recommended depending on the requirements of your application. For overhead use, always install two secure chains that can hold at least 10 times the weight of the fixture.

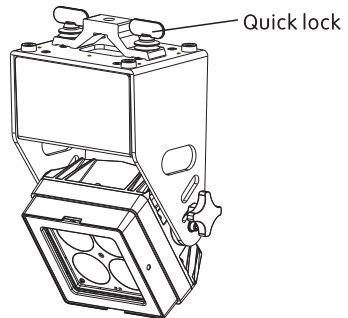

2.1-2

AUTO Controls:

- Select from 【AUTO 01】 to 【AUTO 06】 to play required play function
- Select 【SPEED (+)】 or 【SPEED (-)】 to adjust speed play function.

# 5 EASYPLAY REMOTE CONTROL

## 5.1 KEY FUNCTIONS

Here are three function module:

### STATIC MODE:

- It can be static dimmer, choose static mode and enter into static dimmer
- As instruction, it includes R+,R-,G+,G-,B+,B-,L+,L-and 【R+、R-】 is for red dimmer, 【G+、G-】 is for green dimmer, 【B+、B-】 is for blue dimmer, 【L+、L-】 is for lime dimmer, please refer to above 【RED】、【GREEN】、【BLUE】、【LIME】、

### Section effect mode:

This mode is for preset section effect; As bellowed picture shows, the section mode include preset effect 1-6 button and dimmer + /dimmer -;

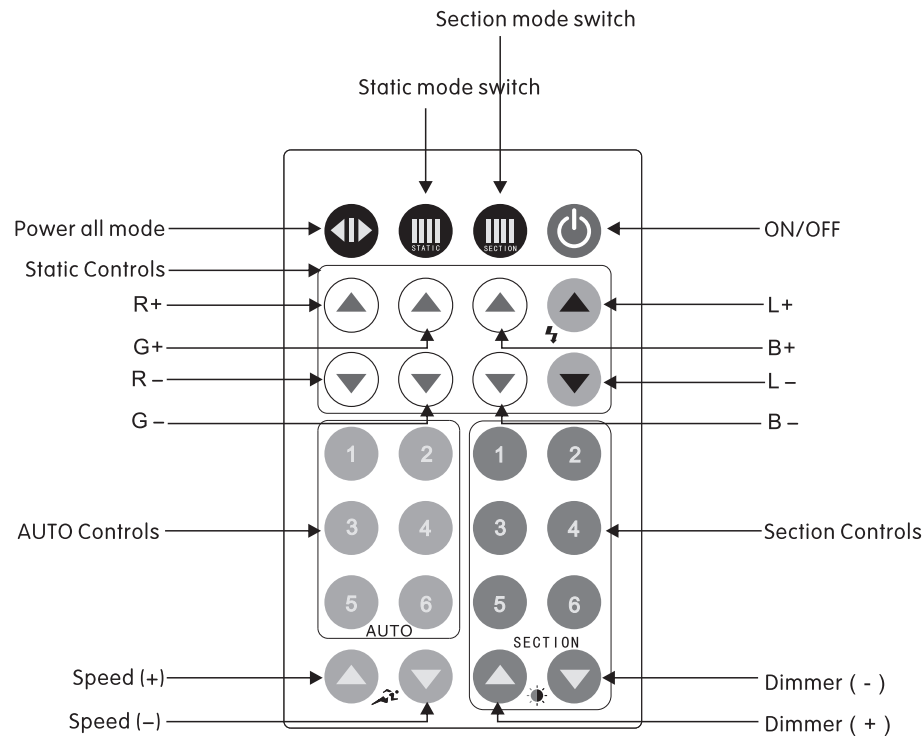

# 3 DISPLAYPANEL OPERATION

## 3.1 BASIC ( TOUCH )



- ◆MENU: Choose one or return to the previous menu;
- ◆ENTER: Choose enter;
- ◆UP: scroll 'UP' through the menu list or increase the value of the current function
- ◆DOWN: scroll 'DOWN' through the menu list or decrease the value of the current function

## 3.2 MENU

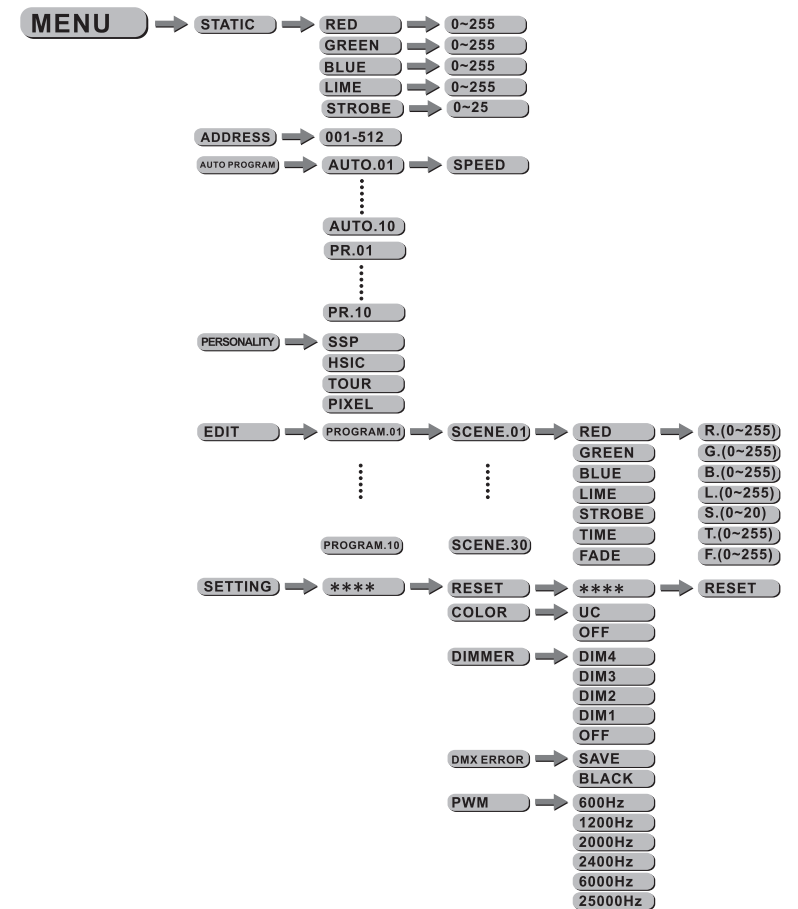

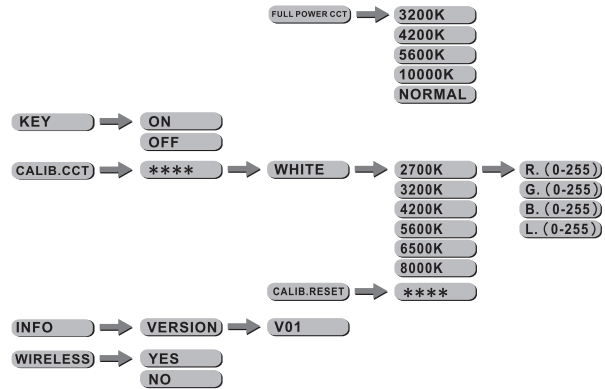

### 3.3 EDIT STATIC COLOUR



- Combine [ RED ], [ GREEN ], [ BLUE ] AND [ LIME ] to create an infinite range of colors (0-255)
- Set the value of the [ STROBE ] (0-25)

### 3.4 DMX512 SETTINGS



- Enter the [ ADDRESS ] mode to set the DMX ADDRESS.

CHANNEL	VALUE	EFFECT
8	250 ↔ 255	8000k as the running color 2-1, The background color can be related to the color for #1.#2.#3.#4.#5.#6.#7.#10.#11 LEDs.
		AUTO
9	0 ↔ 40	NO FUNCTION
	41 ↔ 50	ATUO1
	51 ↔ 60	ATUO2
	61 ↔ 70	ATUO3
	71 ↔ 80	ATUO4
	81 ↔ 90	ATUO5
	91 ↔ 100	ATUO6
	101 ↔ 110	ATUO7
	111 ↔ 120	ATUO8
	121 ↔ 130	ATUO9
	131 ↔ 140	ATUO10
	141 ↔ 150	PROGRAM1
	151 ↔ 160	PROGRAM2
	161 ↔ 170	PROGRAM3
	171 ↔ 180	PROGRAM4
	181 ↔ 190	PROGRAM5
	191 ↔ 200	PROGRAM6
	201 ↔ 210	PROGRAM7
	211 ↔ 220	PROGRAM8
	221 ↔ 230	PROGRAM9
231 ↔ 255	PROGRAM10	
10	0 ↔ 255	AUTO SPEED ADJUSTMENT
11		DIMMER SPEED
	0 ↔ 9	NO FUNCTION
	10 ↔ 29	OFF
	30 ↔ 69	DIM1
	70 ↔ 129	DIM2
	130 ↔ 189	DIM3
	190 ↔ 255	DIM4

## TOUR

CHANNEL	VALUE	EFFECT
1	0 ↔ 255	MASTER DIMMER
2	0 ↔ 255	RED
3	0 ↔ 255	GREEN
4	0 ↔ 255	BLUE
5	0 ↔ 255	LIME
6		MARCOS
	0 ↔ 9	NO FUNCTION
	10 ↔ 29	RED 100% / GREEN UP / BLUE 0%
	30 ↔ 49	RED DOWN / GREEN 100% / BLUE 0%
	50 ↔ 69	RED 0% / GREEN 100% / BLUE UP
	70 ↔ 89	RED 0% / GREEN DOWN / BLUE 100%
	90 ↔ 109	RED UP / GREEN 0% / BLUE 100%
	110 ↔ 129	RED 100% / GREEN 0% / BLUE DOWN
	130 ↔ 149	RED 100% / GREEN UP / BLUE UP
	150 ↔ 169	RED DOWN / GREEN DOWN / BLUE 100%
	170 ↔ 189	ALL LED AT FULL OUTPUT
	190 ↔ 199	2700K
	200 ↔ 209	3200K
	210 ↔ 219	4200K
	220 ↔ 229	5600K
230 ↔ 239	6500K	
240 ↔ 255	8000K	
7		STROBE
	0 ↔ 9	NO FUNCTION
	10 ↔ 99	STROBE FROM (SLOD TO FAST, 0-25Hz)
	100 ↔ 109	NO FUNCTION
	110 ↔ 179	LIGHTNING STROBE
	180 ↔ 189	NO FUNCTION
190 ↔ 255	RANDOM STROBE	
8		PIXEL EFFECT
	0 ↔ 9	NO FUNCTION
	10 ↔ 39	STATIC 1
	40 ↔ 69	STATIC 2
	70 ↔ 99	STATIC ALL
	100 ↔ 129	AUTO 1-2
	130 ↔ 159	AUTO 2-1
	160 ↔ 189	2700k as the running color 1-2, The background color can be related to the color for #1.#2.#3.#4.#5.#6.#7.#10.#11 LEDs.
	190 ↔ 219	2700k as the running color 2-1, The background color can be related to the color for #1.#2.#3.#4.#5.#6.#7.#10.#11 LEDs.
220 ↔ 249	8000k as the running color 1-2, The background color can be related to the color for #1.#2.#3.#4.#5.#6.#7.#10.#11 LEDs.	

## 3.5 ACTIVATING AUTO PROGRAMS

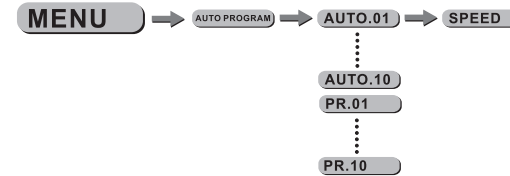

- Select the target [ AUTO PROGRAM ] program and press [ ENTER ] .
- Programs [ AUTO.01 ] to [ AUTO.10 ] are fully pre-programmed and will not be altered by changes in [ EDIT ] mode.
- Programs [ PR.01 ] to [ PR.10 ] are fully pre-programmed and can be edited in [ EDIT ] mode.

## 3.6 PERSONALITY



- Enter the [ PERSONALITY ] mode to select DMX mode: [ SSP ] \ [ HSIC ] \ [ TOUR ] \ [ PIXEL ] .

### 3.7 EDITING CUSTOM PROGRAMS

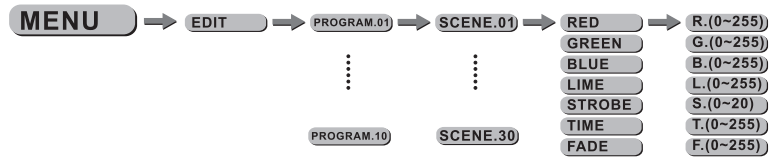

- Enter the **【EDIT】** mode to edit the custom programs **【PROGRAM01】** to **【PROGRAM10】**.
- Each custom program has 30 scenes that can be edited.
- Each step allows the creation of a scene using **RED【RED】**, **GREEN【GREEN】**, **BLUE【BLUE】**, **LIME【LIME】**, **STROBE【STROBE】**, **TIME【TIME】** & **FADE【FADE】**.

### PIXEL

CHANNEL	VALUE	FUNCTION
1	0 ↔ 255	DIMMER
		STROBE
2	0 ↔ 9	NO FUNCTION
	10 ↔ 99	STROBE FROM ( SLOD TO FAST , 0-25Hz )
	100 ↔ 109	NO FUNCTION
	110 ↔ 179	LIGHTNING STROBE
	180 ↔ 189	NO FUNCTION
	190 ↔ 255	RANDOM STROBOBE
3	0 ↔ 255	RED1
4	0 ↔ 255	GREEN1
5	0 ↔ 255	BLUE1
6	0 ↔ 255	LIME1
7	0 ↔ 255	RED2
8	0 ↔ 255	GREEN2
9	0 ↔ 255	BLUE2
10	0 ↔ 255	LIME2
11		DIMMER SPEED
	0 ↔ 9	NO FUNCTION
	10 ↔ 29	OFF
	30 ↔ 69	DIM1
	70 ↔ 129	DIM2
	130 ↔ 189	DIM3
190 ↔ 255	DIM4	

### 3.8 SPECIAL SETTINGS

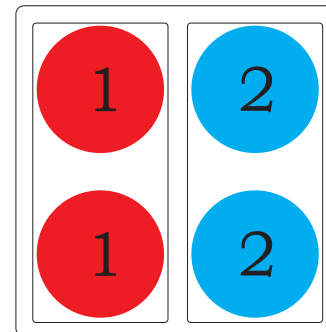
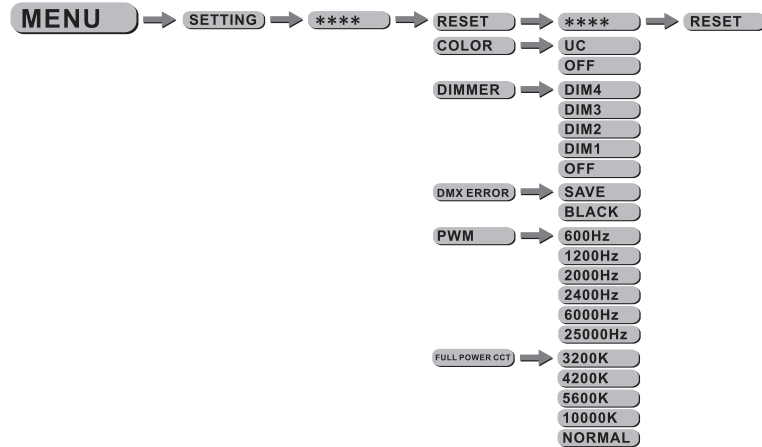



## HSIC

CHANNEL	VALUE	FUNCTION
1	0 ↔ 255	INTENSIYT
2	0 ↔ 255	HUE
3	0 ↔ 255	HUE FINE
4	0 ↔ 255	SATURATION
5		CCT
	0 ↔ 10	NO FUNCTION
	11 ↔ 50	2700K
	51 ↔ 90	3200K
	91 ↔ 130	4200K
	131 ↔ 170	5600K
	171 ↔ 210	6500K
211 ↔ 255	8000K	
6		STROBE
	0 ↔ 9	NO FUNCTION
	10 ↔ 99	STROBE FROM ( SLOW TO FAST , 0-25Hz )
	100 ↔ 109	NO FUNCTION
	110 ↔ 179	LIGHTNING STROBE
	180 ↔ 189	NO FUNCTION
190 ↔ 255	RANDOM STROBE	
7		DIMMER SPEED
	0 ↔ 9	NO FUNCTION
	10 ↔ 29	OFF
	30 ↔ 69	DIM1
	70 ↔ 129	DIM2
	130 ↔ 189	DIM3
190 ↔ 255	DIM4	

- [SETTING]...this menu allows the user to adjust key operation settings for this fixture.
- In order to reset custom modes to default values select [RESET] .  
Note: [UC]\[RGBW]\[CALIB.C] can't reset
- [COLOR] is for activate/unactivate the color calibration functions. When [RGL] is selected, on RGB = 255,255,255, the color is displayed as calibrated in CALIB.C -- RGL. When [COLOR] is set [OFF], on RGB = 255,255,255, the RGB values are not adjusted and the output is most powerful. When [UC] is selected, the RGB output are adjusted to a standard preset universal color which balances fixtures from different generations.  
Note: [COLOR] work only when choose [NORMAL] at [FULL POWER CCT]
- Select [DIM1], [DIM2], [DIM3] or [DIM4] for different dimming speeds. ([DIM4] is the slowest dimming speed)
- [DMX ERROR] Choose [SAVE] in order to save the last DMX data in case of DMX signal error. Choose [BLACK] in order to blackout in case of DMX signal error.
- <PWM> is PWM refresh rate bottom, press UP/DOWN to choose <600Hz>, <1200Hz>, <2000Hz>, <2400Hz>, <6000Hz>, <25000Hz>  
Note: with refresh rate increased, gray rate of dimmer will be reduced, (that's means high refresh rate, low gray rate), when it's <2400Hz>, CV3 is invalid, when it's <25000Hz>, CV1 CV2 CV3 are invalid, so please lower PWM rate to increase gray rate in necessary.
- <FULL POWER CCT> is the color temperature choose bottom, press UP/DOWN to choose, under full power, <3200K>, <4200K>, <5600K>, <10000K> can be chosen, when choose <COLOR>, <3200K>, <4200K>, <5600K> are not work, but choose <NORMAL>.

### 3.9 ACTIVATE THE PASSWORD



- Enter the [ KEY ] mode to select whether the access password is on or off.
- When the fixture is set as PASS [ ON ], after 30 seconds or turn on the fixture next time, the fixture will need an access password to enter the display menu control.  
Note: The factory access password is [ UP ] + [ DOWN ] + [ UP ] + [ DOWN ], then press [ ENTER ] to confirm the access.

### 3.10 BALANCE PARAMETERS AND CORRECTION MENU DISPLAY

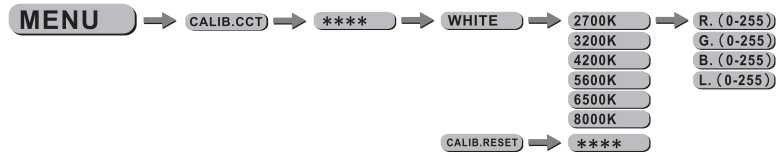

- Enter the [ CALIB.C ] to select white color of different color temperature.
- There are 12 pre-programmed White colors can be edited by using [ RED ] , [ GREEN ] , [ BLUE ] & [ WHITE ]

Note: if CCT data is changed in [ WHITE ] from WT.01 to WT.12, CCT of according channel will be changed also

### 3.11 INFO



- Press [ ENTER ] and go to [ INFO ] ,you can check [ VERSION ] .

### 3.12 WIRELESS



- Press [ ENTER ] and enter [ WIRELESS ] ,choose [ NO ] means no reset,choose [ YES ] means reset

## 4 USING A DMX512 CONTROLLER

### 4.1 CHANNEL ASSIGNMENT

- Note: This product have four DMX512 channel configuration: [ SSP ] , [ HSIC ] , [ TOUR ] , [ PIXEL ]

#### SSP

CHANNEL	VALUE	FUNCTION
1	0 ↔ 255	MASTER DIMMER
2	0 ↔ 255	RED
3	0 ↔ 255	GREEN
4	0 ↔ 255	BLUE
5	0 ↔ 255	LIME
7		STROBE
	0 ↔ 9	NO FUNCTION
	10 ↔ 99	STROBE FROM ( SLOW TO FAST , 0-25Hz )
	100 ↔ 109	NO FUNCTION
	110 ↔ 179	LIGHTNING STROBE
	180 ↔ 189	NO FUNCTION
190 ↔ 255	RANDOM STROBE	
8		DIMMER SPEED
	0 ↔ 9	NO FUNCTION
	10 ↔ 29	OFF
	30 ↔ 69	DIM1
	70 ↔ 129	DIM2
	130 ↔ 189	DIM3
	190 ↔ 255	DIM4