

5 APPENDIX

5 1 MAINTENANCE

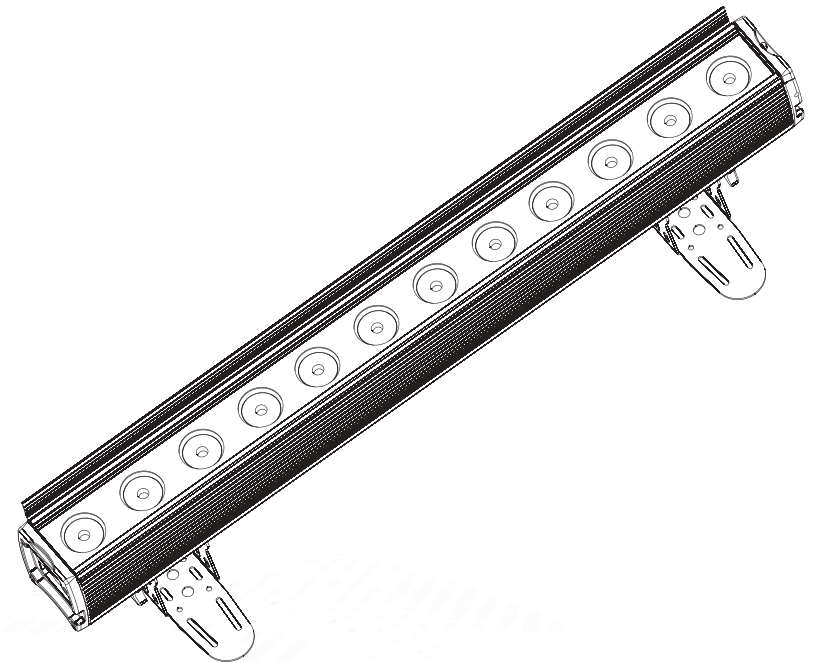
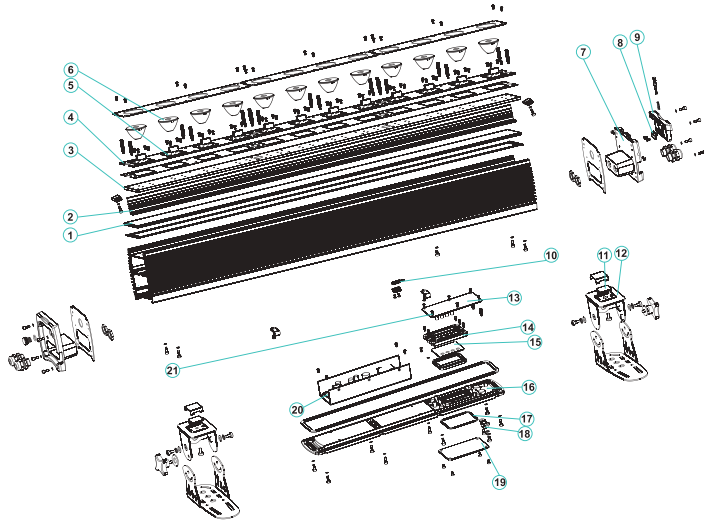

PixCYC 12 Outdoor

USER MANUAL

1 PRODUCT (GENERAL)

1.1 TECHNICAL SPECIFICATIONS

LED MODULE

Type	Voltage	IP	Operation Temperature	Weight (KG)	Dimensions 2 (mm)	Power (W)	Model (pcs)
SS359XCET	AC100~240V 50/60hz	IP66	-20~45	10.5	1000x200x249	150	RGBW*12PCS

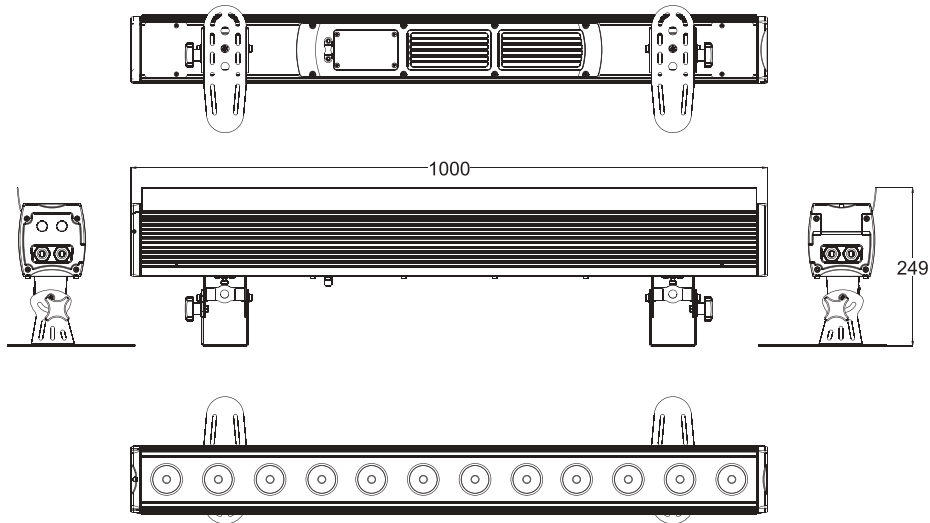

HALO

CHANNEL	VALUE	FUNCTION
1	0 ⇄ 255	PIXEL 1 2700K
2	0 ⇄ 255	PIXEL 2 2700K
3	0 ⇄ 255	PIXEL 3 2700K
4	0 ⇄ 255	PIXEL 4 2700K
5	0 ⇄ 255	PIXEL 5 2700K
6	0 ⇄ 255	PIXEL 6 2700K
7	0 ⇄ 255	PIXEL 7 2700K
8	0 ⇄ 255	PIXEL 8 2700K
9	0 ⇄ 255	PIXEL 9 2700K
10	0 ⇄ 255	PIXEL 10 2700K
11	0 ⇄ 255	PIXEL 11 2700K
12	0 ⇄ 255	PIXEL 12 2700K

1.2 SAFETY WARNING

CHANNEL	VALUE	FUNCTION
51		DIMMER SPEED
	0 ↔ 9	NO FUNCTION
	10 ↔ 29	OFF
	30 ↔ 69	DIM1
	70 ↔ 129	DIM2
	130 ↔ 189	DIM3
	190 ↔ 255	DIM4

ARC1

CHANNEL	VALUE	FUNCTION
1	0 ↔ 255	RED
2	0 ↔ 255	GREEN
3	0 ↔ 255	BLUE

ARC1.D

CHANNEL	VALUE	FUNCTION
1	0 ↔ 255	MASTER DIMMER
2	0 ↔ 255	RED
3	0 ↔ 255	GREEN
4	0 ↔ 255	BLUE

ARC2

CHANNEL	VALUE	FUNCTION
1	0 ↔ 255	RED
2	0 ↔ 255	GREEN
3	0 ↔ 255	BLUE
4	0 ↔ 255	WHITE

IMPORTANT:

- This product must be installed by a qualified professional.
- All maintenance must be carried out by a qualified electrician.
- A minimum distance of 0.5m must be maintained between the equipment and a combustible surface.
- The product must always be operated in a well ventilated area.
- DO NOT stare directly into the LED light source.
- Always disconnect the power before carrying out any maintenance.
- The earth must always be connected to the ground.
- Ensure that all parts of the equipment are kept clean and free of dust.

2 INSTALLATION

2.1 MOUNTING

HANGING

The fixture can be mounted in a hanging position using the supporting bracket. The bracket should be secured to the mounting truss or structure using a standard mounting clamp. Please note that when hanging the unit a safety cable should also be used.

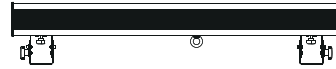

UPRIGHT

The fixture can be mounted in an upright or sitting position using the supporting brackets.



The LED MODULE can be mounted at any angle and in any position. It is possible to further adjust the angle of the LED MODULE using the two adjustment knobs located on the side of the fixture.

2.2 POWER CONNECTIONS

@ 220V: 8 units may be connected in series

@120V: 4 units may be connected in series

CHANNEL	VALUE	FUNCTION
12	0 ↔ 255	GREEN3
13	0 ↔ 255	BLUE3
14	0 ↔ 255	WHITE3
15	0 ↔ 255	RED4
16	0 ↔ 255	GREEN4
17	0 ↔ 255	BLUE4
18	0 ↔ 255	WHITE4
19	0 ↔ 255	RED5
20	0 ↔ 255	GREEN5
21	0 ↔ 255	BLUE5
22	0 ↔ 255	WHITE5
23	0 ↔ 255	RED6
24	0 ↔ 255	GREEN6
25	0 ↔ 255	BLUE6
26	0 ↔ 255	WHITE6
27	0 ↔ 255	RED7
28	0 ↔ 255	GREEN7
29	0 ↔ 255	BLUE7
30	0 ↔ 255	WHITE7
31	0 ↔ 255	RED8
32	0 ↔ 255	GREEN8
33	0 ↔ 255	BLUE8
34	0 ↔ 255	WHITE8
35	0 ↔ 255	RED9
36	0 ↔ 255	GREEN9
37	0 ↔ 255	BLUE9
38	0 ↔ 255	WHITE9
39	0 ↔ 255	RED10
40	0 ↔ 255	GREEN10
41	0 ↔ 255	BLUE10
42	0 ↔ 255	WHITE10
43	0 ↔ 255	RED11
44	0 ↔ 255	GREEN11
45	0 ↔ 255	BLUE11
46	0 ↔ 255	WHITE11
47	0 ↔ 255	RED12
48	0 ↔ 255	GREEN12
49	0 ↔ 255	BLUE12
50	0 ↔ 255	WHITE12

PIXEL.2

CHANNEL	VALUE	FUNCTION
1	0 ↔ 255	DIMMER
		STROBE1
2	0 ↔ 9	NO FUNCTION
	10 ↔ 99	STROBE FROM (SLOD TO FAST)
	100 ↔ 109	NO FUNCTION
	110 ↔ 179	LIGHTNING STROBE
	180 ↔ 189	NO FUNCTION
	190 ↔ 255	RANDOM STROBE
		STROBE2
	0 ↔ 9	0
	10 ↔ 19	1
	20 ↔ 29	2
	30 ↔ 39	3
	40 ↔ 49	4
	50 ↔ 59	5
	60 ↔ 69	6
	70 ↔ 79	7
	80 ↔ 89	8
	90 ↔ 99	9
	100 ↔ 109	10
	110 ↔ 119	11
	120 ↔ 129	12
130 ↔ 139	13	
140 ↔ 149	14	
150 ↔ 159	15	
160 ↔ 169	16	
170 ↔ 179	17	
180 ↔ 189	18	
190 ↔ 199	19	
200 ↔ 255	20	
3	0 ↔ 255	RED1
4	0 ↔ 255	GREEN1
5	0 ↔ 255	BLUE1
6	0 ↔ 255	WHITE1
7	0 ↔ 255	RED2
8	0 ↔ 255	GREEN2
9	0 ↔ 255	BLUE2
10	0 ↔ 255	WHITE2
11	0 ↔ 255	RED3

2.3 SETTING UP WITH A DMX512 CONTROLLER

- Connect the DMX512 controller to the units in series.
- Each unit has N DMX channels so the DMX Addresses should increase by increments of 1, (Nx1)+1, (Nx2)+1, (Nx3)+1, ...
- The ID address has not been set so therefore when using the controller CH 10 must be inactive (CH10=0).
- It is also possible to deactivate ID address selecting **【ID OFF】** from the **【Settings】** menu. on the fixture
- Each DMX Address may be used as many times as required.
- Any DMX address in the range from 001 to 512 may be used.

Example:

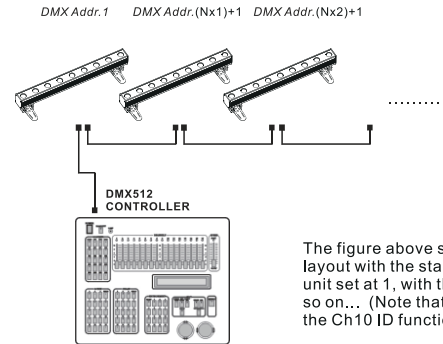

The figure above shows a simple DMX512 layout with the starting address of the first unit set at 1, with the second set at (Nx1)+1 and so on... (Note that when used in this way, the Ch10 ID function must be inactive (CH10=0))

3 DISPLAY PANEL OPERATION

3.1 DISPLAY OPERATION

- 【 MENU 】 return to the previous menu.
- 【 ENTER 】 enter the currently selected menu.
- 【 UP 】 scroll down through the current menu list or decrease the value of the current function.
- 【 DOWN 】 scroll up through the current menu list or Increase the value of the current function.

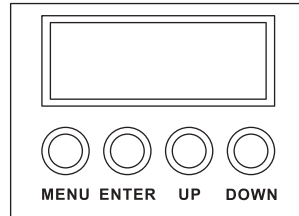

3.2 MENU MAP

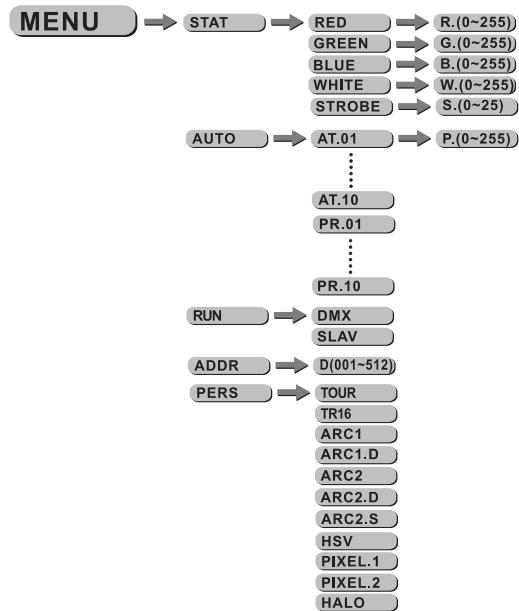

CHANNEL	VALUE	FUNCTION
12	0 ↔ 255	RED4
13	0 ↔ 255	GREEN4
14	0 ↔ 255	BLUE4
15	0 ↔ 255	RED5
16	0 ↔ 255	GREEN5
17	0 ↔ 255	BLUE5
18	0 ↔ 255	RED6
19	0 ↔ 255	GREEN6
20	0 ↔ 255	BLUE6
21	0 ↔ 255	RED7
22	0 ↔ 255	GREEN7
23	0 ↔ 255	BLUE7
24	0 ↔ 255	RED8
25	0 ↔ 255	GREEN8
26	0 ↔ 255	BLUE8
27	0 ↔ 255	RED9
28	0 ↔ 255	GREEN9
29	0 ↔ 255	BLUE9
30	0 ↔ 255	RED10
31	0 ↔ 255	GREEN10
32	0 ↔ 255	BLUE10
33	0 ↔ 255	RED11
34	0 ↔ 255	GREEN11
35	0 ↔ 255	BLUE11
36	0 ↔ 255	RED12
37	0 ↔ 255	GREEN12
38	0 ↔ 255	BLUE12
39		DIMMER SPEED
	0 ↔ 9	NO FUNCTION
	10 ↔ 29	OFF
	30 ↔ 69	DIM1
	70 ↔ 129	DIM2
	130 ↔ 189	DIM3
190 ↔ 255	DIM4	

PIXEL.1

CHANNEL	VALUE	FUNCTION
1	0 ↔ 255	DIMMER
		STROBE1
	0 ↔ 9	NO FUNCTION
	10 ↔ 99	STROBE FROM (SLOD TO FAST)
	100 ↔ 109	NO FUNCTION
	110 ↔ 179	LIGHTNING STROBE
	180 ↔ 189	NO FUNCTION
	190 ↔ 255	RANDOM STROBE
		STROBE2
2	0 ↔ 9	0
	10 ↔ 19	1
	20 ↔ 29	2
	30 ↔ 39	3
	40 ↔ 49	4
	50 ↔ 59	5
	60 ↔ 69	6
	70 ↔ 79	7
	80 ↔ 89	8
	90 ↔ 99	9
	100 ↔ 109	10
	110 ↔ 119	11
	120 ↔ 129	12
	130 ↔ 139	13
	140 ↔ 149	14
	150 ↔ 159	15
	160 ↔ 169	16
	170 ↔ 179	17
	180 ↔ 189	18
	190 ↔ 199	19
200 ↔ 255	20	
3	0 ↔ 255	RED1
4	0 ↔ 255	GREEN1
5	0 ↔ 255	BLUE1
6	0 ↔ 255	RED2
7	0 ↔ 255	GREEN2
8	0 ↔ 255	BLUE2
9	0 ↔ 255	RED3
10	0 ↔ 255	GREEN3
11	0 ↔ 255	BLUE3

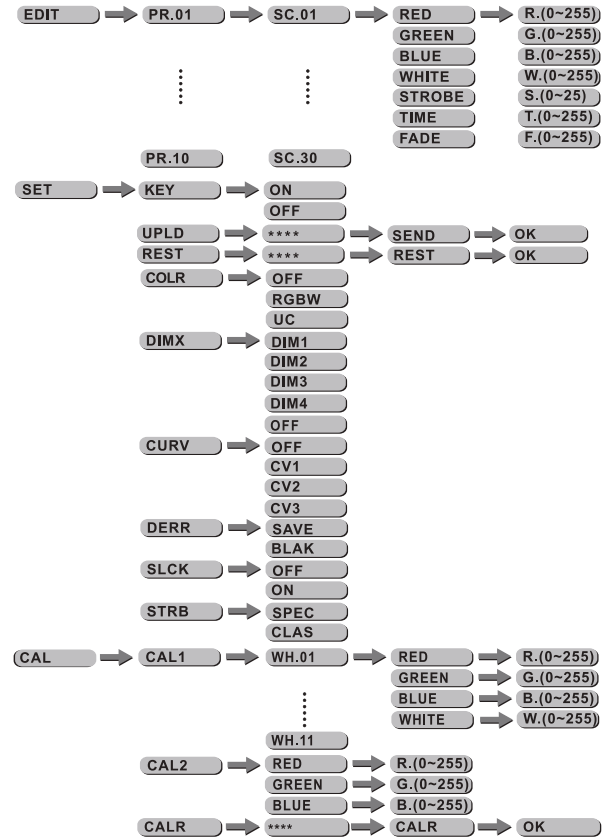

3.3 EDIT STATIC COLOUR



- Combine **Red** , **Green** , **Blue** and **White** to create an infinite range of colors (0-255)
- Set the value of the **Strobe** (0-25Hz)

3.4 ACTIVATING AUTO PROGRAMS

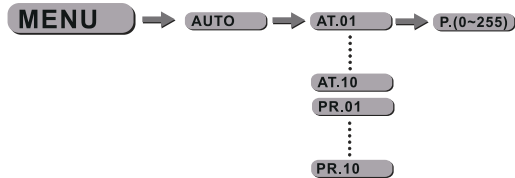

- Select the target **AUTO** program and press **ENTER** .
- Programs **AT.01** to **AT.10** are fully pre-programmed and will not be altered by changes in **EDIT** mode.
- Programs **PR.01** to **PR.10** are fully pre-programmed and can be edited in **EDIT** mode.

3.5 RUN MODE



- Enter the **RUN** mode to set working mode.
- **DMX** mode is for using the DMX512 controller to control the fixtures.
- **SLAV** mode is for Master -- Slave operation.

CHANNEL	VALUE	FUNCTION
16	205 ⇔ 209	PIX10,11,12(STATIC)
	210 ⇔ 214	PIX1,2,3,4(STATIC)
	215 ⇔ 219	PIX5,6,7,8(STATIC)
	220 ⇔ 224	PIX9,10,11,12(STATIC)
	225 ⇔ 229	PIX1,2,3,4,5,6(STATIC)
	230 ⇔ 234	PIX7,8,9,10,11,12(STATIC)
	235 ⇔ 239	RANDOM
	240 ⇔ 255	PIX 1,2,3,4,5,6,7,8,9,10,11,12(STATIC)

ARC2.D

CHANNEL	VALUE	FUNCTION
1	0 ⇔ 255	MASTER DIMMER
2	0 ⇔ 255	RED
3	0 ⇔ 255	GREEN
4	0 ⇔ 255	BLUE
5	0 ⇔ 255	WHITE

ARC2.S

CHANNEL	VALUE	FUNCTION
1	0 ⇔ 255	MASTER DIMMER
2	0 ⇔ 255	RED
3	0 ⇔ 255	GREEN
4	0 ⇔ 255	BLUE
5	0 ⇔ 255	WHITE
6	0 ⇔ 255	STROBE2

HSV

CHANNEL	VALUE	FUNCTION
1	0 ⇔ 255	HUE
2	0 ⇔ 255	STATURATION
3	0 ⇔ 255	VALUE

CHANNEL	VALUE	FUNCTION
		PIXEL SELECTION
	0 ⇔ 9	PIX 1,2,3,4,5,6,7,8,9,10,11,12(STATIC)
	10 ⇔ 14	PIX 1
	15 ⇔ 19	PIX 1,4(STATIC)
	20 ⇔ 24	PIX 1,5(STATIC)
	25 ⇔ 29	PIX 1,6(STATIC)
	30 ⇔ 34	PIX 1,7(STATIC)
	35 ⇔ 39	PIX 1,4,7,10(STATIC)
	40 ⇔ 44	PIX 1,3,5,7,9,11(STATIC)
	45 ⇔ 49	PIX 2,4,6,8,10,12(STATIC)
	50 ⇔ 54	PIX 1,2(STATIC)
	55 ⇔ 59	PIX 1,2,3(STATIC)
	60 ⇔ 64	PIX 1,2,3,4(STATIC)
	65 ⇔ 69	PIX 1,2,3,4,5,6,7,8,9,10,11,12(STATIC)
	70 ⇔ 74	PIX 1
	75 ⇔ 79	PIX 2
	80 ⇔ 84	PIX 3
	85 ⇔ 89	PIX 4
16	90 ⇔ 94	PIX 5
	95 ⇔ 99	PIX 6
	100 ⇔ 104	PIX 7
	105 ⇔ 109	PIX 8
	110 ⇔ 114	PIX 9
	115 ⇔ 119	PIX 10
	120 ⇔ 124	PIX 11
	125 ⇔ 129	PIX 12
	130 ⇔ 134	PIX1,2(STATIC)
	135 ⇔ 139	PIX3,4(STATIC)
	140 ⇔ 144	PIX5,6(STATIC)
	145 ⇔ 149	PIX7,8(STATIC)
	150 ⇔ 154	PIX9,10(STATIC)
	155 ⇔ 159	PIX11,12(STATIC)
	160 ⇔ 164	PIX 1,3(STATIC)
	165 ⇔ 169	PIX 2,4(STATIC)
	170 ⇔ 174	PIX 5,7(STATIC)
	175 ⇔ 179	PIX 6,8(STATIC)
	180 ⇔ 184	PIX 9,11(STATIC)
	185 ⇔ 189	PIX 10,12(STATIC)
	190 ⇔ 194	PIX1,2,3(STATIC)
	195 ⇔ 199	PIX4,5,6(STATIC)
	200 ⇔ 204	PIX7,8,9(STATIC)

3.6 DMX512 SETTINGS



- Enter the **【ADDR】** mode to set the DMX ADDRESS.

3.7 PERSONALITY

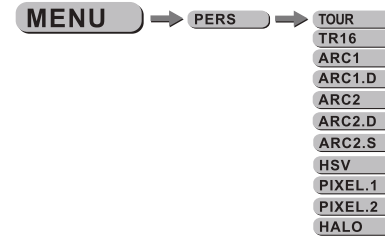

- Enter the **【PERSONALITY】** mode to select DMX mode: **【TOUR】**, **【TR16】**, **【ARC1】**, **【ARC1.D】**, **【ARC2】**, **【ARC2.D】**, **【ARC2.S】**, **【HSV】**, **【PIXEL.1】**, **【PIXEL.2】**, **【HALO】**.

3.8 EDITING CUSTOM PROGRAMS



- Enter the **【EDIT】** mode to edit the custom programs **【PR.01】** to **【PR.10】**.
- Each custom program has 30 steps that can be edited.
- Each step allows the creation of a scene using RED **【Red】**, GREEN **【Green】**, BLUE **【Blue】**, WHITE **【White】**, STROBE **【Strobe】**, TIME **【Time】** & FADE **【Fade】**.

3.9 SPECIAL SETTINGS

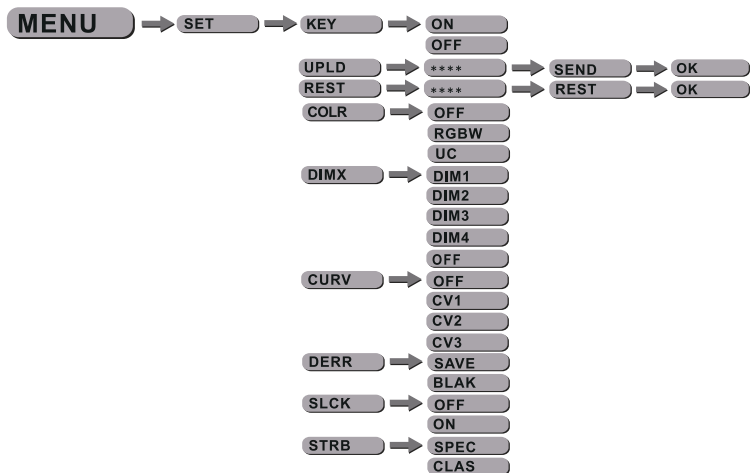

- [SET]...this menu allows the user to adjust key operation settings for this fixture. [KEY]...select [ON] for automatic lock-out. Password to re-enter the display is <UP> + <DOWN> + <UP> + <DOWN>.
- Select[UPLD] to upload the custom programs from the current MASTER unit to the SLAVE units.
- In order to reset custom modes to default values select [REST].
- [COLR] is for activate/unactivate the color calibration functions. When [RGBW] is selected, on RGB = 255,255,255, the color is displayed as calibrated in CAL2 -- RGBW. When[COLR] is set [OFF], on RGB = 255,255,255, the RGB values are not adjusted and the output is most powerful. When [UC] is selected, the RGB output are adjusted to a standard preset universal color which balances fixtures from different generations.
- Select [DIM1], [DIM2], [DIM3] or [DIM4] for different dimming speeds. ([DIM4] is the slowest dimming speed)
- [CURV] allows the user to adjust the shape of the dimming curve. See the CURV chart to understand more about actual dimming curves.
- [DERR] Choose[Save] in order to save the last DMX data in case of DMX signal error. Choose[Black] in order to blackout in case of DMX signal error.
- [SLCK] is used to lock the settings menu. When [SLCK] is set to [ON] then user must insert passcode (UP+DOWN+UP+DOWN) in order to access the settings menu.
- [STRB] This fixture allows for two different strobe personality settings, [CLAS] strobe or [SPEC] strobe. The [STRB] settings are only valid in the DMX personalities [TOUR], [AR2.S] and [Tr16]

CHANNEL	VALUE	FUNCTION
13	166 ↔ 169	Green background, illuminance adjustable. 100% red lightness runs (12-1)
	170 ↔ 173	Green background, illuminance adjustable. 100% red lightness runs (1-12-1)
	174 ↔ 177	Green background, illuminance adjustable. 100% red lightness runs (1-6,12-1), 1&12 light up in the same time, gathering from 2 sides to the center in turn. When it is at 6,7, spreading from the center to the 2 sides, associated with CH1~CH8
	178 ↔ 181	Blue background, illuminance adjustable. 100% red lightness runs (1-12)
	182 ↔ 185	Blue background, illuminance adjustable. 100% red lightness runs (12-1)
	186 ↔ 189	Blue background, illuminance adjustable. 100% red lightness runs (1-12-1)
	190 ↔ 193	Blue background, illuminance adjustable. 100% red lightness runs (1-6,12-1), 1&12 light up in the same time, gathering from 2 sides to the center in turn. When it is at 6,7, spreading from the center to the 2 sides, associated with CH1~CH8
	194 ↔ 197	(1,2)-(3,4)-(5,6)-(7,8)-(9,10),(11,12)
	198 ↔ 201	(1,2,3)-(4,5,6)-(7,8,9)-(10,11,12)
	202 ↔ 205	(1,2,3,4)-(5,6,7,8)-(9,10,11,12)
	206 ↔ 209	(12,11)-(10,9)-(8,7)-(6,5)-(4,3),(2,1)
	210 ↔ 213	(12,11,10)-(9,8,7)-(6,5,4,3)-(3,2,1)
	214 ↔ 217	(12,11,10,9)-(8,7,6,5)-(4,3,2,1)
	218 ↔ 221	1,2 from left to right, 11,12 from right to left
	222 ↔ 225	1,2,3 from left to right, 10,11,12 from right to left
	226 ↔ 229	1,2,3,4 from left to right, 9,10,11,12 from right to left
	230 ↔ 233	1-6RED, 7-12BLUE
	234 ↔ 237	1-6ORANGE, 7-12CYAN
	238 ↔ 241	1-6YELLOW, 7-12PURPLE
	242 ↔ 245	1-6GREEN, 7-12ORANGE
246 ↔ 249	1-6CYAN, 7-12RED	
250 ↔ 253	1-6BLUE, 7-12YELLOW	
254 ↔ 255	1-6PURPLE, 7-12GREEN	
14	0 ↔ 255	AUTO SPEED ADJUSTMENT
15		DIMMER SPEED
	0 ↔ 9	NO FUNCTION
	10 ↔ 29	OFF
	30 ↔ 69	DIM1
	70 ↔ 129	DIM2
	130 ↔ 189	DIM3
190 ↔ 255	DIM4	

CHANNEL	VALUE	FUNCTION
13	90 ↔ 93	Green background, illuminance adjustable. 100% blue lightness runs (1-12-1)
	94 ↔ 97	Green background, illuminance adjustable. 100% blue lightness runs (1-6, 12-1), 1&12 light up in the same time, gathering from 2sides to the center in turn. When it is at6,7, spreading from the center to the 2 sides, associated with CH1~CH8
	98 ↔ 101	Blue background, illuminance adjustable. 100% green lightness runs (1-12)
	102 ↔ 105	Blue background, illuminance adjustable. 100% green lightness runs (12-1)
	106 ↔ 109	Blue background, illuminance adjustable. 100% green lightness runs (1-12-1)
	110 ↔ 113	Blue background, illuminance adjustable. 100% green lightness runs (1-6, 12-1), 1&12 light up in the same time, gathering from 2sides to the center in turn. When it is at6,7, spreading from the center to the 2 sides, associated with CH1~CH8
	114 ↔ 117	White background, illuminance adjustable. 100% red lightness runs (1-12)
	118 ↔ 121	White background, illuminance adjustable. 100% red lightness runs (12-1)
	122 ↔ 125	White background, illuminance adjustable. 100% red lightness runs (1-12-1)
	126 ↔ 129	White background, illuminance adjustable. 100% red lightness runs (1-6, 12-1), 1&12 light up in the same time, gathering from 2sides to the center in turn. When it is at6,7, spreading from the center to the 2 sides, associated with CH1~CH8
	130 ↔ 133	Green background, illuminance adjustable. 100% blue lightness runs (1-12)
	134 ↔ 137	Green background, illuminance adjustable. 100% blue lightness runs (12-1)
	138 ↔ 141	Green background, illuminance adjustable. 100% blue lightness runs (1-12-1)
	142 ↔ 145	Green background, illuminance adjustable. 100% blue lightness runs (1-6, 12-1), 1&12 light up in the same time, gathering from 2sides to the center in turn. When it is at6,7, spreading from the center to the 2 sides, associated with CH1~CH8
	146 ↔ 149	Blue background, illuminance adjustable. 100% green lightness runs (1-12)
	150 ↔ 153	Blue background, illuminance adjustable. 100% green lightness runs (12-1)
	154 ↔ 157	Blue background, illuminance adjustable. 100% green lightness runs (1-12-1)
	158 ↔ 161	Blue background, illuminance adjustable. 100% green lightness runs (1-6, 12-1), 1&12 light up in the same time, gathering from 2sides to the center in turn. When it is at6,7, spreading from the center to the 2 sides, associated with CH1~CH8
	162 ↔ 165	Green background, illuminance adjustable. 100% red lightness runs (1-12)

3.10 BALANCE PARAMETERS AND CORRECTION MENU DISPLAY

Press **【MENU】** button to enter the password confirmation, to enter the correct password < UP + DOWN + UP + DOWN >
Key, press the **【MENU】** in, the correct password will enter show submenu

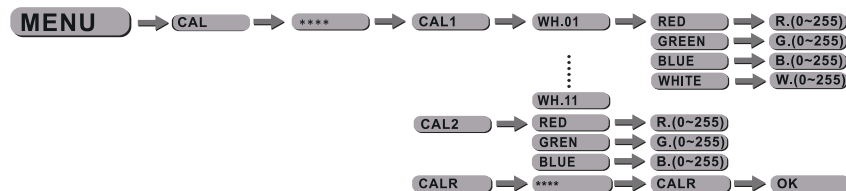

- Enter the **【CAL1】** to select white color of different color temperature.
- There are 11 pre-programmed White colors can be edited by using **【Red】** , **【Green】** , **【Blue】** & **【White】** .
- Enter the **【CAL2】** to adjust the RGB parameter to make different whites default color temperature for **【RGGBW】** color mixing is 5600K.
- When the new setting is activated, the DMX controller choose RGB = 255,255,255 the white color will be made by the actual RGB values on the **【CAL2】** .

4 USING A DMX512 CONTROLLER

4.1 CHANNEL ASSIGNMENT

- Note: This product have many DMX512 channel configuration: TOUR /TR16/ ARC1 / ARC1.D / ARC2 / ARC2.D / ARC2.S / HSV / PIXEL.1 / PIXEL.2 / HALO

TOUR

CHANNEL	VALUE	FUNCTION
1	0 ↔ 255	MASTER DIMMER
2	0 ↔ 255	RED
3	0 ↔ 255	GREEN
4	0 ↔ 255	BLUE
5	0 ↔ 255	WHITE
6		COLOR MACRO
	0 ↔ 10	NO FUNCTION
	11 ↔ 30	RED 100% / GREEN UP / BLUE 0%
	31 ↔ 50	RED DOWN / GREEN 100% / BLUE 0%
	51 ↔ 70	RED 0% / GREEN 100% / BLUE UP
	71 ↔ 90	RED 0% / GREEN DOWN / BLUE 100%
	91 ↔ 110	RED UP / GREEN 0% / BLUE 100%
	111 ↔ 130	RED 100% / GREEN 0% / BLUE DOWN
	131 ↔ 150	RED 100% / GREEN UP / BLUE UP
	151 ↔ 170	RED DOWN / GREEN DOWN / BLUE 100%
	171 ↔ 200	ALL LED AT FULL OUTPUT
	201 ↔ 205	WHITE1: 3200K
	206 ↔ 210	WHITE2: 3400K
	211 ↔ 215	WHITE3: 4200K
	216 ↔ 220	WHITE4: 4900K
	221 ↔ 225	WHITE5: 5600K
	226 ↔ 230	WHITE6: 5900K
	231 ↔ 235	WHITE7: 6500K
236 ↔ 240	WHITE8: 7200K	
241 ↔ 245	WHITE9: 8000K	
246 ↔ 250	WHITE10: 8500K	
251 ↔ 255	WHITE11: 10000K	

CHANNEL	VALUE	FUNCTION
30 ↔ 33		9 (Illuminance 30%) - 8 (Illuminance 60%) 7 (Illuminance 100%) , (associated with CH1 ~ CH8)
		8 (Illuminance 30%) - 7 (Illuminance 60%) 6 (Illuminance 100%) , (associated with CH1 ~ CH8)
		7 (Illuminance 30%) - 6 (Illuminance 60%) 5 (Illuminance 100%) , (associated with CH1 ~ CH8)
		6 (Illuminance 30%) - 5 (Illuminance 60%) 4 (Illuminance 100%) , (associated with CH1 ~ CH8)
		5 (Illuminance 30%) - 4 (Illuminance 60%) 3 (Illuminance 100%) , (associated with CH1 ~ CH8)
		4 (Illuminance 30%) - 3 (Illuminance 60%) 2 (Illuminance 100%) , (associated with CH1 ~ CH8)
		3 (Illuminance 30%) - 2 (Illuminance 60%) 1 (Illuminance 100%) , (associated with CH1 ~ CH8)
34 ↔ 37		1-12(Single 2700K cycling operation, the background effect associated with CH1 ~ CH8)
38 ↔ 41		12-1(Single 2700K cycling operation, the background effect associated with CH1 ~ CH8)
42 ↔ 45		1-12-1(Single 2700K cycling operation, the background effect associated with CH1 ~ CH8)
13	46 ↔ 49	1-6 and 12-7(1<2700K>&12<2700K>light up in the same time, gethering from 2sides to the center in turn. When it is at6,7,spreading from the center to the 2 sides, the background effect associated with CH1~CH8)
	50 ↔ 53	1-12(Single 6000K cycling operation, the background effect associated with CH1 ~ CH8)
	54 ↔ 57	12-1(Single 6000K cycling operation, the background effect associated with CH1 ~ CH8)
	58 ↔ 61	1-12-1(Single 6000K cycling operation, the background effect associated with CH1 ~ CH8)
	62 ↔ 65	1-6 and 12-7(1<6000K>&12<6000K>light up in the same time, gethering from 2sides to the center in turn. When it is at6,7,spreading from the center to the 2 sides, the background effect associated with CH1~CH8)
	66 ↔ 69	Red background, illuminace adjustable. 100% green lightness runs (1-12)
	70 ↔ 73	Red background, illuminace adjustable. 100% green lightness runs (12-1)
	74 ↔ 77	Red background, illuminace adjustable. 100% green lightness runs (1-12-1)
	78 ↔ 81	Red background, illuminace adjustable. 100% green lightness runs (1-6, 12-1),1&12 light up in the same time, gethering from 2sides to the center in turn. When it is at6,7,spreading from the center to the 2 sides, associated with CH1~CH8
	82 ↔ 85	Green background, illuminace adjustable. 100% blue lightness runs (1-12)
	86 ↔ 89	Green background, illuminace adjustable. 100% blue lightness runs (12-1)

CHANNEL	VALUE	FUNCTION
13		PIXEL EFFECT
	0 ↔ 9	NO FUNCTION
	10 ↔ 13	1-12(Single light cycling operation, associated with CH1 ~ CH8)
	14 ↔ 17	12-1(Single light cycling operation, associated with CH1 ~ CH8)
	18 ↔ 21	1-12-1(Single light cycling operation, associated with CH1 ~ CH8)
	22 ↔ 25	1-6 and 12-7(1&12 light up in the same time, gettingher from 2sides to the center in turn. When it is at6,7,spreading from the center to the 2 sides,associated with CH1~CH8)
	26 ↔ 29	1 (Illuminance 30%) - 2 (Illuminance 60%) 3 (Illuminance 100%) , (associated with CH1 ~ CH8)
		2 (Illuminance 30%) - 3 (Illuminance 60%) 4 (Illuminance 100%) , (associated with CH1 ~ CH8)
		3 (Illuminance 30%) - 4 (Illuminance 60%) 5 (Illuminance 100%) , (associated with CH1 ~ CH8)
		4 (Illuminance 30%) - 5 (Illuminance 60%) 6 (Illuminance 100%) , (associated with CH1 ~ CH8)
		5 (Illuminance 30%) - 6 (Illuminance 60%) 7 (Illuminance 100%) , (associated with CH1 ~ CH8)
		6 (Illuminance 30%) - 7 (Illuminance 60%) 8 (Illuminance 100%) , (associated with CH1 ~ CH8)
		7 (Illuminance 30%) - 8 (Illuminance 60%) 9 (Illuminance 100%) , (associated with CH1 ~ CH8)
		8 (Illuminance 30%) - 9 (Illuminance 60%) 10 (Illuminance 100%) , (associated with CH1 ~ CH8)
		9 (Illuminance 30%) - 10 (Illuminance 60%) 11 (Illuminance 100%) , (associated with CH1 ~ CH8)
		10 (Illuminance 30%) - 11 (Illuminance 60%) 12 (Illuminance 100%) , (associated with CH1 ~ CH8)
	30 ↔ 33	12 (Illuminance 30%) - 11 (Illuminance 60%) 10 (Illuminance 100%) , (associated with CH1 ~ CH8)
		11 (Illuminance 30%) - 10 (Illuminance 60%) 9 (Illuminance 100%) , (associated with CH1 ~ CH8)
		10 (Illuminance 30%) - 9 (Illuminance 60%) 8 (Illuminance 100%) , (associated with CH1 ~ CH8)

CHANNEL	VALUE	FUNCTION
7		STROBE 1
	0 ↔ 9	NO FUNCTION
	10 ↔ 99	STROBE FROM (SLOD TO FAST , 0~25Hz)
	100 ↔ 109	NO FUNCTION
	110 ↔ 179	LIGHTNING STROBE
	180 ↔ 189	NO FUNCTION
	190 ↔ 255	RANDOM STROBE
		STROBE 2
	0 ↔ 9	0
	10 ↔ 19	1
	20 ↔ 29	2
	30 ↔ 39	3
	40 ↔ 49	4
	50 ↔ 59	5
	60 ↔ 69	6
	70 ↔ 79	7
	80 ↔ 89	8
	90 ↔ 99	9
	100 ↔ 109	10
	110 ↔ 119	11
120 ↔ 129	12	
130 ↔ 139	13	
140 ↔ 149	14	
150 ↔ 159	15	
160 ↔ 169	16	
170 ↔ 179	17	
180 ↔ 189	18	
190 ↔ 199	19	
200 ↔ 255	20	
8		PIXEL EFFECT
	0 ↔ 9	NO FUNCTION
	10 ↔ 13	1-12(Single light cycling operation, associated with CH1 ~ CH8)
	14 ↔ 17	12-1(Single light cycling operation, associated with CH1 ~ CH8)
	18 ↔ 21	1-12-1(Single light cycling operation, associated with CH1 ~ CH8)
	22 ↔ 25	1-6 and 12-7(1&12 light up in the same time, gettingher from 2sides to the center in turn. When it is at6,7,spreading from the center to the 2 sides,associated with CH1~CH8)
26 ↔ 29	1 (Illuminance 30%) - 2 (Illuminance 60%) 3 (Illuminance 100%) , (associated with CH1 ~ CH8)	

CHANNEL	VALUE	FUNCTION
8	26 ↔ 29	2 (Illuminance 30%) - 3 (Illuminance 60%) 4 (Illuminance 100%) , (associated with CH1 ~ CH8)
		3 (Illuminance 30%) - 4 (Illuminance 60%) 5 (Illuminance 100%) , (associated with CH1 ~ CH8)
		4 (Illuminance 30%) - 5 (Illuminance 60%) 6 (Illuminance 100%) , (associated with CH1 ~ CH8)
		5 (Illuminance 30%) - 6 (Illuminance 60%) 7 (Illuminance 100%) , (associated with CH1 ~ CH8)
		6 (Illuminance 30%) - 7 (Illuminance 60%) 8 (Illuminance 100%) , (associated with CH1 ~ CH8)
		7 (Illuminance 30%) - 8 (Illuminance 60%) 9 (Illuminance 100%) , (associated with CH1 ~ CH8)
		8 (Illuminance 30%) - 9 (Illuminance 60%) 10 (Illuminance 100%) , (associated with CH1 ~ CH8)
		9 (Illuminance 30%) - 10 (Illuminance 60%) 11 (Illuminance 100%) , (associated with CH1 ~ CH8)
		10 (Illuminance 30%) - 11 (Illuminance 60%) 12 (Illuminance 100%) , (associated with CH1 ~ CH8)
		30 ↔ 33
	11 (Illuminance 30%) - 10 (Illuminance 60%) 9 (Illuminance 100%) , (associated with CH1 ~ CH8)	
	10 (Illuminance 30%) - 9 (Illuminance 60%) 8 (Illuminance 100%) , (associated with CH1 ~ CH8)	
	9 (Illuminance 30%) - 8 (Illuminance 60%) 7 (Illuminance 100%) , (associated with CH1 ~ CH8)	
	8 (Illuminance 30%) - 7 (Illuminance 60%) 6 (Illuminance 100%) , (associated with CH1 ~ CH8)	
	7 (Illuminance 30%) - 6 (Illuminance 60%) 5 (Illuminance 100%) , (associated with CH1 ~ CH8)	
	6 (Illuminance 30%) - 5 (Illuminance 60%) 4 (Illuminance 100%) , (associated with CH1 ~ CH8)	
	5 (Illuminance 30%) - 4 (Illuminance 60%) 3 (Illuminance 100%) , (associated with CH1 ~ CH8)	
	4 (Illuminance 30%) - 3 (Illuminance 60%) 2 (Illuminance 100%) , (associated with CH1 ~ CH8)	
	3 (Illuminance 30%) - 2 (Illuminance 60%) 1 (Illuminance 100%) , (associated with CH1 ~ CH8)	
	34 ↔ 37	1-12(Single 2700K cycling operation, the background effect associated with CH1 ~ CH8)
	38 ↔ 41	12-1(Single 2700K cycling operation, the background effect associated with CH1 ~ CH8)
	42 ↔ 45	1-12-1(Single 2700K cycling operation, the background effect associated with CH1 ~ CH8)
	46 ↔ 49	1-6 and 12-7(1<2700K>&12<2700K>light up in the same time, gethering from 2sides to the center in turn. When it is at6,7,spreading from the center to the 2 sides, the background effect associated with CH1~CH8)

CHANNEL	VALUE	FUNCTION
11	216 ↔ 220	WHITE4: 4900K
	221 ↔ 225	WHITE5: 5600K
	226 ↔ 230	WHITE6: 5900K
	231 ↔ 235	WHITE7: 6500K
	236 ↔ 240	WHITE8: 7200K
	241 ↔ 245	WHITE9: 8000K
	246 ↔ 250	WHITE10: 8500K
251 ↔ 255	WHITE11: 10000K	
12		STROBE 1
	0 ↔ 9	NO FUNCTION
	10 ↔ 99	STROBE FROM (SLOD TO FAST)
	100 ↔ 109	NO FUNCTION
	110 ↔ 179	LIGHTNING STROBE
	180 ↔ 189	NO FUNCTION
	190 ↔ 255	RANDOM STROBE
		STROBE 2
	0 ↔ 9	0
	10 ↔ 19	1
	20 ↔ 29	2
	30 ↔ 39	3
	40 ↔ 49	4
	50 ↔ 59	5
	60 ↔ 69	6
	70 ↔ 79	7
	80 ↔ 89	8
	90 ↔ 99	9
	100 ↔ 109	10
	110 ↔ 119	11
120 ↔ 129	12	
130 ↔ 139	13	
140 ↔ 149	14	
150 ↔ 159	15	
160 ↔ 169	16	
170 ↔ 179	17	
180 ↔ 189	18	
190 ↔ 199	19	
200 ↔ 255	20	

CHANNEL	VALUE	FUNCTION
11	170 ↔ 177	PIX7,8,9(STATIC)
	178 ↔ 185	PIX10,11,12(STATIC)
	186 ↔ 193	PIX1,2,3,4(STATIC)
	194 ↔ 201	PIX5,6,7,8(STATIC)
	202 ↔ 209	PIX9,10,11,12(STATIC)
	210 ↔ 217	PIX1,2,3,4,5,6(STATIC)
	218 ↔ 225	PIX7,8,9,10,11,12(STATIC)
	226 ↔ 234	RANDOM
	235 ↔ 255	PIX 1,2,3,4,5,6,7,8,9,10,11,12(STATIC)

TR16

CHANNEL	VALUE	FUNCTION
1	0 ↔ 255	MASTER DIMMER
2	0 ↔ 255	MASTER DIMMER FINE
3	0 ↔ 255	RED
4	0 ↔ 255	RED FINE
5	0 ↔ 255	GREEN
6	0 ↔ 255	GREEN FINE
7	0 ↔ 255	BLUE
8	0 ↔ 255	BLUE FINE
9	0 ↔ 255	WHITE
10	0 ↔ 255	WHITE FINE
11		COLOR MARCOS
	0 ↔ 10	NO FUNCTION
	11 ↔ 30	RED 100% / GREEN UP / BLUE 0%
	31 ↔ 50	RED DOWN / GREEN 100% / BLUE 0%
	51 ↔ 70	RED 0% / GREEN 100% / BLUE UP
	71 ↔ 90	RED 0% / GREEN DOWN / BLUE 100%
	91 ↔ 110	RED UP / GREEN 0% / BLUE 100%
	111 ↔ 130	RED 100% / GREEN 0% / BLUE DOWN
	131 ↔ 150	RED 100% / GREEN UP / BLUE UP
	151 ↔ 170	RED DOWN / GREEN DOWN / BLUE 100%
	171 ↔ 200	ALL LED AT FULL OUTPUT
	201 ↔ 205	WHITE1: 3200K
	206 ↔ 210	WHITE2: 3400K
	211 ↔ 215	WHITE3: 4200K

CHANNEL	VALUE	FUNCTION
8	50 ↔ 53	1-12(Single 6000K cycling operation, the background effect associated with CH1 ~ CH8)
	54 ↔ 57	12-1(Single 6000K cycling operation, the background effect associated with CH1 ~ CH8)
	58 ↔ 61	1-12-1(Single 6000K cycling operation, the background effect associated with CH1 ~ CH8)
	62 ↔ 65	1-6 and 12-7(1<6000K>&12<6000K>light up in the same time, gathering from 2sides to the center in turn. When it is at6,7,spreading from the center to the 2 sides, the background effect associated with CH1~CH8)
	66 ↔ 69	Red background, illuminace adjustable. 100% green lightness runs (1-12)
	70 ↔ 73	Red background, illuminace adjustable. 100% green lightness runs (12-1)
	74 ↔ 77	Red background, illuminace adjustable. 100% green lightness runs (1-12-1)
	78 ↔ 81	Red background, illuminace adjustable. 100% green lightness runs (1-6,12-1),1&12 light up in the same time, gathering from 2sides to the center in turn. When it is at6,7,spreading from the center to the 2 sides, associated with CH1~CH8
	82 ↔ 85	Green background, illuminace adjustable. 100% blue lightness runs (1-12)
	86 ↔ 89	Green background, illuminace adjustable. 100% blue lightness runs (12-1)
	90 ↔ 93	Green background, illuminace adjustable. 100% blue lightness runs (1-12-1)
	94 ↔ 97	Green background, illuminace adjustable. 100% blue lightness runs (1-6,12-1),1&12 light up in the same time, gathering from 2sides to the center in turn. When it is at6,7,spreading from the center to the 2 sides, associated with CH1~CH8
	98 ↔ 101	Blue background, illuminace adjustable. 100% green lightness runs (1-12)
	102 ↔ 105	Blue background, illuminace adjustable. 100% green lightness runs (12-1)
	106 ↔ 109	Blue background, illuminace adjustable. 100% green lightness runs (1-12-1)
	110 ↔ 113	Blue background, illuminace adjustable. 100% green lightness runs (1-6,12-1),1&12 light up in the same time, gathering from 2sides to the center in turn. When it is at6,7,spreading from the center to the 2 sides, associated with CH1~CH8
	114 ↔ 117	White background, illuminace adjustable. 100% red lightness runs (1-12)
118 ↔ 121	White background, illuminace adjustable. 100% red lightness runs (12-1)	
122 ↔ 125	White background, illuminace adjustable. 100% red lightness runs (1-12-1)	
126 ↔ 129	White background, illuminace adjustable. 100% red lightness runs (1-6,12-1),1&12 light up in the same time, gathering from 2sides to the center in turn. When it is at6,7,spreading from the center to the 2 sides, associated with CH1~CH8	

CHANNEL	VALUE	FUNCTION
8	130 ↔ 133	Green background, illuminance adjustable. 100% blue lightness runs (1-12)
	134 ↔ 137	Green background, illuminance adjustable. 100% blue lightness runs (12-1)
	138 ↔ 141	Green background, illuminance adjustable. 100% blue lightness runs (1-12-1)
	142 ↔ 145	Green background, illuminance adjustable. 100% blue lightness runs (1-6,12-1),1&12 light up in the same time, gathering from 2sides to the center in turn. When it is at6,7,spreading from the center to the 2 sides, associated with CH1~CH8
	146 ↔ 149	Blue background, illuminance adjustable. 100% green lightness runs (1-12)
	150 ↔ 153	Blue background, illuminance adjustable. 100% green lightness runs (12-1)
	154 ↔ 157	Blue background, illuminance adjustable. 100% green lightness runs (1-12-1)
	158 ↔ 161	Blue background, illuminance adjustable. 100% green lightness runs (1-6,12-1),1&12 light up in the same time, gathering from 2sides to the center in turn. When it is at6,7,spreading from the center to the 2 sides, associated with CH1~CH8
	162 ↔ 165	Green background, illuminance adjustable. 100% red lightness runs (1-12)
	166 ↔ 169	Green background, illuminance adjustable. 100% red lightness runs (12-1)
	170 ↔ 173	Green background, illuminance adjustable. 100% red lightness runs (1-12-1)
	174 ↔ 177	Green background, illuminance adjustable. 100% red lightness runs (1-6,12-1),1&12 light up in the same time, gathering from 2sides to the center in turn. When it is at6,7,spreading from the center to the 2 sides, associated with CH1~CH8
	178 ↔ 181	Blue background, illuminance adjustable. 100% red lightness runs (1-12)
	182 ↔ 185	Blue background, illuminance adjustable. 100% red lightness runs (12-1)
	186 ↔ 189	Blue background, illuminance adjustable. 100% red lightness runs (1-12-1)
	190 ↔ 193	Blue background, illuminance adjustable. 100% red lightness runs (1-6,12-1),1&12 light up in the same time, gathering from 2sides to the center in turn. When it is at6,7,spreading from the center to the 2 sides, associated with CH1~CH8
	194 ↔ 197	(1,2)-(3,4)-(5,6)-(7,8)-(9,10),(11,12)
	198 ↔ 201	(1,2,3)-(4,5,6)-(7,8,9)-(10,11,12)
	202 ↔ 205	(1,2,3,4)-(5,6,7,8)-(9,10,11,12)
	206 ↔ 209	(12,11)-(10,9)-(8,7)-(6,5)-(4,3),(2,1)
210 ↔ 213	(12,11,10)-(9,8,7)-(6,5,4,)-(3,2,1)	

CHANNEL	VALUE	FUNCTION
8	214 ↔ 217	(12,11,10,9)-(8,7,6,5)-(4,3,2,1)
	218 ↔ 221	1,2from left to right, 11,12from right to left
	222 ↔ 225	1,2,3from left to right, 10,11,12from right to left
	226 ↔ 229	1,2,3,4from left to right, 9,10,11,12from right to left
	230 ↔ 233	1-6RED, 7-12BLUE
	234 ↔ 237	1-6ORANGE, 7-12CYAN
	238 ↔ 241	1-6YELLOW, 7-12PURPLE
	242 ↔ 245	1-6GREEN, 7-12ORANGE
	246 ↔ 249	1-6CYAN, 7-12RED
	250 ↔ 253	1-6BLUE, 7-12YELLOW
254 ↔ 255	1-6PURPLE, 7-12GREEN	
9	0 ↔ 255	AUTO SPEED ADJUSTMENT
10		DIMMER SPEED
	0 ↔ 9	NO FUNCTION
	10 ↔ 29	OFF
	30 ↔ 69	DIM1
	70 ↔ 129	DIM2
	130 ↔ 189	DIM3
190 ↔ 255	DIM4	
11		PIXEL SELECTION
	0 ↔ 9	PIX 1,2,3,4,5,6,7,8,9,10,11,12(STATIC)
	10 ↔ 17	PIX 1
	18 ↔ 25	PIX 2
	26 ↔ 33	PIX 3
	34 ↔ 41	PIX 4
	42 ↔ 49	PIX 5
	50 ↔ 57	PIX 6
	58 ↔ 65	PIX 7
	66 ↔ 73	PIX 8
	74 ↔ 81	PIX 9
	82 ↔ 89	PIX 10
	90 ↔ 97	PIX 11
	98 ↔ 105	PIX 12
	106 ↔ 113	PIX1,2(STATIC)
	114 ↔ 121	PIX3,4(STATIC)
	122 ↔ 129	PIX5,6(STATIC)
130 ↔ 137	PIX7,8(STATIC)	
138 ↔ 145	PIX9,10(STATIC)	
146 ↔ 153	PIX11,12(STATIC)	
154 ↔ 161	PIX1,2,3(STATIC)	
162 ↔ 169	PIX4,5,6(STATIC)	